



- **Integrated HV Supply, Filament Supply, X-Ray Tube, Beam Port and Control Electronics**
- **Compact & Lightweight**
- **Universal input, Power Factor Corrected with Internal EMI Filter**
- **Can be Mounted in Any Physical Orientation**
- **Analog Control Interface and Standard RS-232 Digital Interface**

Spellman's XRB100N100 Monoblock® X-Ray source is designed for OEM applications powering its internal X-Ray tube up to 100kV at 100W. Features like universal input, small package size and a standard analog and RS-232 digital interface simplify integrating this Monoblock® into your X-Ray system. Proprietary emission control circuitry provides excellent regulation of X-Ray tube current, along with outstanding stability performance.

TYPICAL APPLICATIONS

X-Ray Scanning: Food Inspection, Fill Level Confirmation and Security Applications

SPECIFICATIONS

X-Ray Characteristics:

Tube Type:	Stationary anode, tungsten target
Focal Spot:	0.5mm (IEC 336)
Beam Filter:	Lexan: 3.2mm Oil: 10mm ±0.1mm Glass: 1.8mm max
Beam Geometry:	Symmetrical fan 74° x 10° ±1°

Input Voltage:

Power factor corrected input 0.98, 100-240Vac ±10%
50/60Hz, 2A, maximum

X-Ray Tube Voltage:

Nominal X-Ray tube voltage is adjustable between
40kV to 100kV

X-Ray Tube Current:

100uA to 1mA over specified tube voltage range

X-Ray Tube Power:

100W maximum continuous

Voltage Regulation:

Line:	±0.1% of maximum output voltage over a ±10% change of nominal input line voltage
Load:	±0.1% of maximum rated voltage for 100uA to 1mA load change

Voltage Accuracy:

Voltage measured across the X-Ray tube is within
±2% of the programmed value

Voltage Risetime:

Ramp time shall be 1 second from 10% to
90% of maximum rated output voltage

Voltage Overshoot:

5% of maximum voltage, to return within 2.5% of
maximum voltage in less than 50ms

Voltage Ripple:

0.5% peak to peak of maximum voltage for
frequencies ≤1kHz

Emission Current Parameters

Current Regulation:

Line:	±0.5% of rated output current over a ±10% change of nominal input line voltage
Load:	±0.5% of rated output current for a change from 50% to 100% of rated output voltage

Current Accuracy:

Current measured through the X-Ray tube is within
±1% of the programmed value

Current Risetime:

Ramp time shall be 1 second from 10% to 90%
of maximum rated current

Arc Intervention:

3 arcs in 10 seconds with a 200ms quench = Shutdown

Filament Configuration:

Internal high frequency AC filament drive with closed loop
filament emission control

Analog Interface:

Ground referenced 0 to 9Vdc for all programming and monitoring signals. Relay contacts and open collector signals for other signals. See analog interface connector pin out table.

Digital Interface:

Jumpers are needed to be configured and the digital interface cable installed to enable the RS-232 interface.

Control Software:

A demo GUI is available for engineering evaluations.

Interlock/Signals:

A hardware interlock functions in both analog and digital programming modes. The hardware X-Ray Enable signal only functions in analog programming mode.

Operating Temperature:

0°C to +40°C

Storage Temperature:

-40°C to +70°C

Humidity:

10% to 95% relative humidity, non-condensing

Cooling:

Forced air and natural convection augmented by customer provided external cooling fan to maintain oil temperature below 55°C.

Input Line Connector:

3 pin, Phoenix Contact 1829167, SHV part number 105725-219. Mating connector Phoenix Contact #1805990, SHV part number 105808-475 provided with unit.

Analog Interface Connector:

15 pin D connector, male

Digital Interface Connector:

9 pin D connector, female

Grounding Point:

M4 ground stud provided on chassis

Dimensions:

See page 3 of 3

Weight:

55lbs (25kg)

Orientation:

Can be mounted in any orientation.

X-Ray Leakage:

Not to be greater than 0.5mR/hr at 5cm outside the external surface.

**AC LINE POWER CONNECTOR—
J1 THREE POSITION PHOENIX CONTACT**

PIN	SIGNAL
1	Earth Ground
2	Line
3	Neutral

Mating connector provided with unit

**RS-232 DIGITAL INTERFACE—
J3 9 PIN FEMALE D CONNECTOR**

PIN	SIGNAL	PARAMETERS
1	N/C	No Connection
2	TD	Transmit Data
3	RD	Receive Data
4	N/C	No Connection
5	SGND	Signal Ground
6	NC	No Connection
7	NC	No Connection
8	NC	No Connection
9	NC	No Connection

**XRB ANALOG INTERFACE—
J2 15 PIN MALE D CONNECTOR**

PIN	SIGNAL	PARAMETERS
1	Power Supply Fault Output	Open collector, 35V @ 10mA max. high = no fault
2	mA Program Input	0 to 9.00Vdc = 0 to 100% rated output, Zin = 10MΩ
3	kV Program Input	0 to 9.00Vdc = 0 to 100% rated output, Zin = 10MΩ
4	X-Ray On Lamp Relay Output	Common, dry contacts, 30Vdc @ 1A, max
5	X-Ray On Lamp Relay Output	Normally open, X-Ray ON = closed
6	mA Monitor Output	0 to 9Vdc = 0 to 100% rated output, Zout = 10kΩ
7	X-Ray On Lamp Relay Output	Normally closed, X-Ray ON = open
8	kV Monitor Output	0 to 9.00Vdc = 0 to 100% rated output, Zout = 10kΩ
9	Signal Ground	Ground
10	Signal Ground	Ground
11	HV Interlock Return Input	Connect to Pin 12 to close HV interlock
12	HV Interlock Output	+15Vdc @ open, 5mA when connected to pin 11
13	X-Ray Enable Output	+15Vdc @ open, 5mA when connected to pin 15
14	X-Ray Status Output	Open collector, 35V @ 10mA max high = X-Ray OFF
15	X-Ray Enable Return Input	Connect to pin 13 to enable X-Ray generation

LED INDICATORS

INDICATOR	SIGNAL NAME	CONDITION Illuminated When...
LED 1	OV	High kV occurs
LED 2	UV	Low kV occurs
LED 3	UC	Low mA occurs
LED 4	OC	High mA occurs
LED 5	ARC FLT	Arc fault occurs
LED 6	OT	Over temperature occurs
LED 7	X-RAY ON	X-Rays are enabled
LED 8	PWR	Power is ON

DIMENSIONS: in.[mm]

**X-RAY GENERATOR
FRONT VIEW**

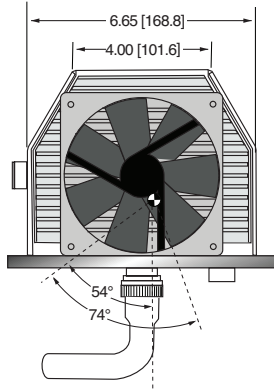

TOP VIEW

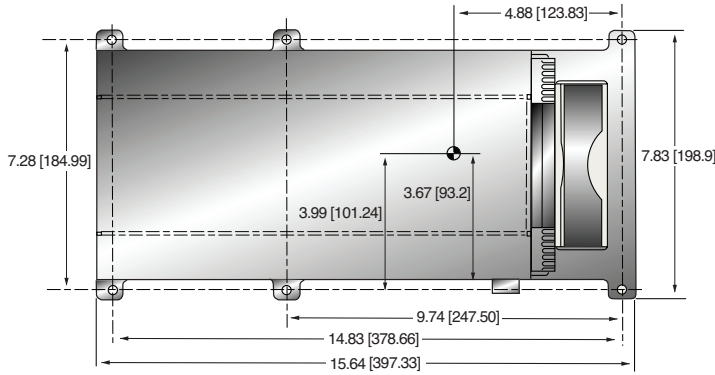

SIDE VIEW

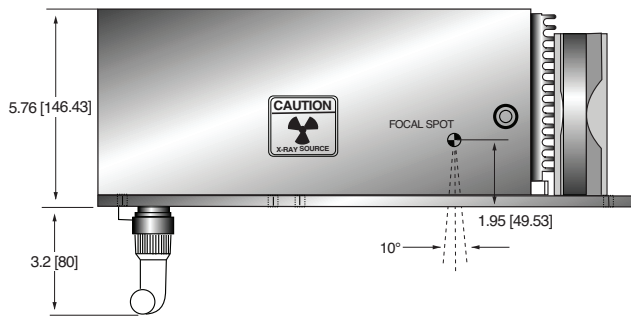

BOTTOM VIEW

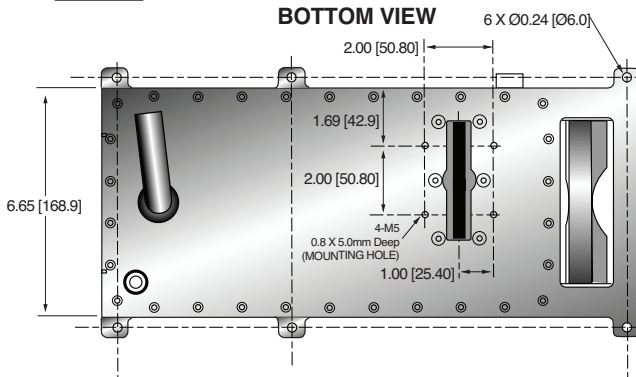

**CONTROL UNIT
FRONT VIEW**

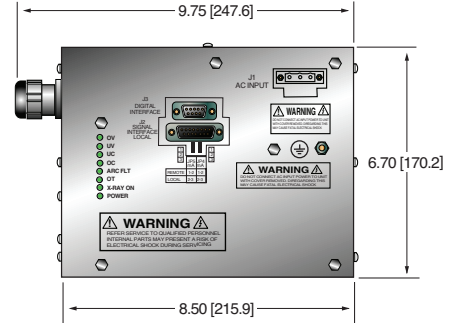

TOP VIEW



SIDE VIEW

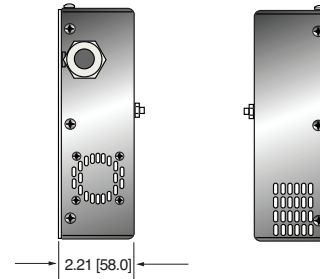

BOTTOM VIEW

