



- **Integrated Tetrode Supply for Field Emission SEM**
- **Very Low Ripple and Ultra Stable Outputs**
- **Robust Arc and Short Circuit Protection**
- **Designed to Minimize Micro-discharge Events**
- **RS-232 Digital Interface**
- **Free GUI for Testing and Development Work**
- **CE, UKCA and RoHS Marked**

Spellman's EBM60-FEG Series is an integrated, multiple high voltage power supply specifically designed to drive Field Emission Scanning Electron Microscope (SEM) columns. Spellman's extensive applications knowledge has enabled us to develop a range of technology platforms that can be customized to meet the demanding requirements of SEM.

The main Acceleration Voltage is a high stability 60kV supply, with integrated floating Filament, Extractor and Suppressor outputs required to drive Field Emission, Cold Cathode and Schottky Electron Sources. All outputs are offered with ultra-low output ripple, minimal micro-discharge, excellent regulation, stability, temperature coefficient and accuracy specifications for unprecedented image quality and resolution. Isolation and control of the respective floating sources is provided via Spellman's proprietary high voltage isolation techniques.

Customer control of this integrated EBM60-FEG power supply system is accomplished via an RS-232 interface. The unit is CE and UKCA marked.

TYPICAL APPLICATIONS

Scanning Electron Microscopes (SEM)
Electron Beam Controller

SPECIFICATIONS

Input Voltage:

100 to 240 Vac $\pm 10\%$ @1A max. 50 to 60 Hz $\pm 5\%$

Environmental:

Operating Temperature:

+10°C to +45°C ambient for normal operation.

The unit will operate from 0°C but will require an extended warm up period.

Storage Temperature:

-25°C to +60°C

Humidity:

0 to 85% RH, non-condensing

Mechanical:

The unit can be operated in any orientation.

Front Panel Indicators:

- Power On
- Interlocks enabled (both interlocks are closed)
- HV On (any of the HV outputs are enabled)
- Warning (any of the internal warning levels exceeded)
- Operating (unit running correctly)
- Trip
- Fault
- Serial Bus (communication taking place)

Status Outputs:

The unit has three digital outputs to indicate status conditions through TTL signals (high when the corresponding LED is illuminated)

- 1- HV on
- 2- Fault
- 3- Unit Operating

Test GUI:

A product GUI can be provided free of charge for customer testing and development work.

Interlocks:

Two separate interlocks are provided:

- Gun interlock: 24V output provided for an external volt free interlock
- HV cable interlock: interlock plate mounted over the HV connector

If any interlock is not present: all high voltage supplies including filament are shut down, however communication over the serial interfaces remains operational.

Protection:

- All outputs are protected from arcs in the load (repetition rate up to 0.1 Hz) and continuous short circuit.
- The unit monitors the temperature of the main power semiconductors and shutdown the relevant outputs if a temperature become excessive.
- All low voltage inputs are protected against over voltages of ± 30 Volts.
- The power input is protected against over voltage and reversed connection.

Weight:

86 lbs. (39kg)

Regulatory Approvals:

Compliant to EEC Low Voltage Directive. UK Conformity Assessed. RoHS Compliant.

OUTPUTS SPECIFICATIONS

OUTPUT	Accelerator	Filament	Suppressor	Extractor
Output Voltage	-200V to -60kV referenced to ground	nominal 1V max 1.5V referenced to Accelerator	-10V to -1kV referenced to Beam Energy	200V to 5kV referenced to Beam Energy
Output current - max	300μA	3A	100μA	500μA
Current Trip	350μA ±10% Output disabled and program set to zero	>3.15A for 10s. All outputs disabled and programs set to zero	>120mA ±10% All outputs disabled and programs set to zero	600μA ±10% All outputs disabled and programs set to zero
Accuracy	±5V	±5mA (between 2A to 3A)	±14V	±2%
Linearity	< ± 5V between 500V and 60kV	±10mA	±14V	±2V
Load Regulation	<±10ppm for 30μA to 400μA	<5mA for 10% in load resistance	<± 100ppm for 10μA to 90μA	<± 100ppm for 10μA to 500μA
Line Regulation for a ± 10% line change	<±10ppm	<1mA	<±10ppm	<±10ppm
Ripple p-p at max. output	<120mVp-p at 1Hz to 1MHz	<40mAp-p 20Hz to 10kHz across 0.5Ω @ 2.5A	<10mVp-p at 1Hz to 1MHz	<50mV p-p at 1Hz to 1MHz
Temperature Coefficient	<20 ppm/°C at 60kV after 1h warm up	<20 ppm/°C	<50 ppm/°C	<25 ppm/°C
Stability (1h warm up)	<15ppm or 40mV (whichever is greater) /10min	<30ppm/10min and 5mA/3 months @ 2.5A	<100ppm/10min	<20ppm/10min
Voltage Monitor Resolution	1.14V	62.5μV	19mV	97mV
Voltage Monitor Accuracy	±1% or ±50V	±5% or ±25mV	±0.5% or ±0.5V	±0.5% or ±3V
Current Monitor Resolution	5.7nA	62.5μA	2.3nA	11nA
Current Monitor Accuracy	±1μA	±1% or ±5mA	±2μA	±0.5% or ±2μA
Additional info	Programmable Wobble feature. Sinusoidal, 0V to 500V p-p, 0.2Hz to 2Hz	Open Circuit detection: Vout > 3.1 ± 0.1V All outputs disabled and programs set to zero. Optimized for a nominal load resistance of 0.5Ω		

GUN INTERLOCK CONNECTOR 3 PIN MATE-N-LOK (TE CONN. P/N: 1-350943-0)

PIN	SIGNAL	I/O	PARAMETER
1	Interlock -	I	24V Return
2	N/C	-	
3	Interlock +	O	24V Drive

STATUS OUTPUT CONNECTOR 9 PIN FEMALE D

PIN	SIGNAL	I/O	PARAMETER
1	HV ON	O	High voltage status, logic high* when any of the HV outputs is enabled
2	HV ON GND	-	High voltage status return
3	Fault	O	Fault status, logic high* when any internal fault is detected
4	Fault GND	-	Fault status return
5	UO	O	Unit Operating status, logic high* when the unit is running correctly
6	UO GND	-	Unit Operating status return
7	N/C	-	No connection
8	N/C	-	No connection
9	N/C	-	No connection

*TTL Signal: High > 2.7V, Low < 0.8V

RS-232 COMMUNICATION CONNECTOR 9 PIN MALE D

PIN	SIGNAL	I/O	PARAMETER
1	N/C	-	No connection
2	RS232 RXD	I	RS-232 receive data
3	RS232 TXD	O	RS-232 transmit data
4	N/C	-	No connection
5	GND	-	Ground
6	N/C	-	No connection
7	N/C	-	No connection
8	N/C	-	No connection
9	N/C	-	No connection

INPUT POWER CONNECTOR

I.E.C. 320 Receptacle with integral fuse

HIGH VOLTAGE OUTPUT CONNECTOR

The unit uses a Claymount CA4 75kV 4 pin receptacle. Mating cable assemblies in different lengths are available. See HOW TO ORDER table.

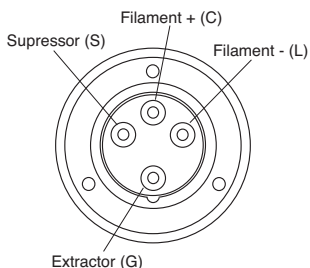

DIMENSIONS: in.[mm]

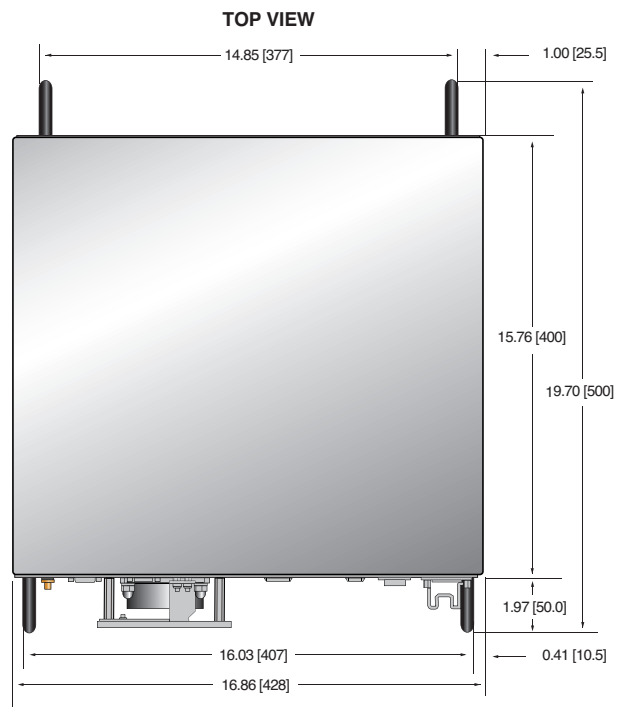
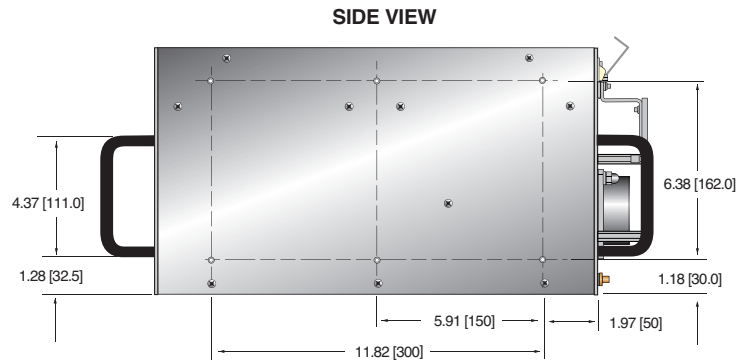

REAR VIEW

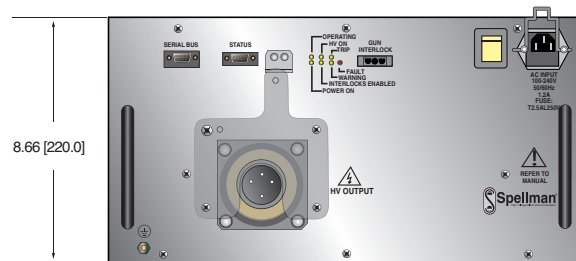

HOW TO ORDER

Description	Part Number
EBM60-FEG	EBM60N18/FEG
HV Output Cable - 3 meters	HVC75/4SO/1365
HV Output Cable - 4 meters	HVC75/4SO/1366